



# PLASTIC RECYCLING MACHINE SOLUTION

## Adina Industries Co., Ltd

### Adina Industries Co., Ltd

Head Office:  
Room 525-527, Xihu International Trade Center, Shangcheng District, Hangzhou City,  
Zhejiang Province, China.

Factory address:  
Chen'aoli Industrial Area, Damaiyu Street, Yuhuan City, Zhejiang Province, China.  
web: [www.adinaindustries.com](http://www.adinaindustries.com)  
E-Mail: [info@adinaindustries.com](mailto:info@adinaindustries.com)



ADINA INDUSTRIES was established in 2016 which is a professional manufacturer of plastic recycling machinery in Zhejiang city, China. Worksite area of 4000m<sup>2</sup>, office 300m<sup>2</sup> and 50+ employees. Pursuing innovation and high quality, we specialize in plastic waste crushing, washing and drying lines, turn-key plant for recycling varies plastics, granulating machines, shredding and crushing system, customized equipment and components.

With over 08 years of experience in plastic recycling & processing equipment, We have supplied machines to 30+ countries: USA, Russia, Mexico, Chile, Brazil, Vietnam, Saudi Arabia, Egypt, Romania, UAE.,etc. We keep upgrading technology to be more competitive to supply more durable machines to customers all over the world. We customize and design machines for you according to your specified requirement.

ADINA INDUSTRIES will be faithful to be your best cooperative partner in plastic recycling plant and create the most value for you!

## WHY CHOOSE US?

### Turnkey Solution

Suggest best solution on machine configuration and design the recycling plant based on clients requirements.  
Offer affordable price, less advertising costs, more benefits to users.

### Sincere communication

No bragging, No exaggeration. We provide suggestion based on our actual production experience and feedback from users.

### Quality assurance

With CE standard, ensure security protection for both operators and machines.  
Mechanical and electrical components are of trusted brand and our long-term suppliers.  
Times of careful test running before delivery.

### Quick Response & Service

Our dynamic term of specialists and technicians are available for online support.  
Providing technical assistance in installation, commission and training.  
Quick response and technician standby for service abroad if needed.



# PP/PE FILM, PP WOVEN BAGS/RAFFIA RECYCLING WASHING LINE

## PP/PE 薄膜, PP编织袋回收清洗生产线

### 设备简介 Equipment Introduction

Highly and normally contaminated PE packing film, agricultural film, drip irrigation pipes, PP jumbo bags, raffia, go through size reduction (shredder/crusher), intensive cleaning by friction (friction washer), rinsing (flotation tank), and drying (hot-air/centrifugal dryer/squeezer), become clean flakes for downstream extrusion and pelletizing process. We supply a variety of plastic washing lines differing in capacity, and your specified requirement.



Centrifugal dryer



Squeezer dryer

### 包含单机 Machines Included

- |                                   |   |  |
|-----------------------------------|---|--|
| <b>1</b> Belt conveyor<br>皮带输送机   | <b>2</b> Shredder<br>撕碎机                      | <b>3</b> Crusher<br>破碎机                      |
| <b>4</b> Screw loader<br>螺旋上料机    | <b>5</b> Sink-float washing tank<br>沉淀漂洗池     | <b>6</b> High-speed friction washer<br>高速搓洗机 |
| <b>7</b> Centrifugal dryer<br>脱水机 | <b>8</b> Hot-air pipe drying system<br>管道烘干系统 | <b>9</b> Squeezer<br>挤干机                     |
| <b>10</b> Storage silo<br>过渡料仓    | <b>11</b> Electrical control cabinet<br>集中控制柜 |  |

### 生产线估算参数 Estimated Plant Parameters

Capacity(kg/h) 产量 (kg/h)	Power installed(kw) 安装功率 (kw)	Required area(m <sup>2</sup> ) 工厂面积 (m <sup>2</sup> )	Manpower 人力	Water supply(m <sup>2</sup> /H) 用水量(m <sup>2</sup> /H)	Final Products 成品
200-300	110-160	350	2-3	4-5	Moisture: 3-10% Particle size: 60-100mm
400-600	160-230	400	3-4	8-10	
800-1000	280-500	750	4-6	15-20	
1500	380-600	1000	6-8	20-30	

# PP/PE RIGID PLASTICS RECYCLING WASHING LINE

## PP/PE 硬杂料回收清洗生产线

### 设备简介 Equipment Introduction

Rigid waste plastics such as HDPE milk bottles, shampoo bottles, chemical barrels, oil pots, PP injection containers, baskets, basins, etc, go through size reduction (shredder/crusher), intensive cleaning by friction (friction washer), rinsing (flotation tank), and drying (hot-air/centrifugal dryer), become clean flakes for downstream extrusion and pelletizing process. We supply a variety of plastic washing lines differing in capacity and your specified requirement.



### 包含单机 Machines Included

- |   |   |  |
|---|---|--|
| <b>1</b> Belt conveyor<br>皮带输送机               | <b>2</b> Shredder<br>撕碎机                      | <b>3</b> Crusher<br>破碎机                      |
| <b>4</b> Screw loader<br>螺旋上料机                | <b>5</b> Sink-float washing tank<br>沉淀漂洗池     | <b>6</b> High-speed friction washer<br>高速搓洗机 |
| <b>7</b> Centrifugal dryer<br>脱水机             | <b>8</b> Hot-air pipe drying system<br>管道烘干系统 | <b>9</b> Storage silo<br>过渡料仓                |
| <b>10</b> Electrical control cabinet<br>集中控制柜 |   |  |

### 生产线估算参数 Estimated Plant Parameters

Capacity(kg/h) 产量 (kg/h)	Power installed(kw) 安装功率 (kw)	Required area(m <sup>2</sup> ) 工厂面积 (m <sup>2</sup> )	Manpower 人力	Water supply(m <sup>2</sup> /H) 用水量(m <sup>2</sup> /H)	Final Products 成品
200-300	100	300	2-3	4-5	Moisture: 1-2% Particle size: 8-16mm
400-500	115	300	2-3	4-5	
800-1000	125	500	3-5	6-8	
1300-1500	180	600	3-5	8-10	
1800-2000	250	800	3-5	10-15	

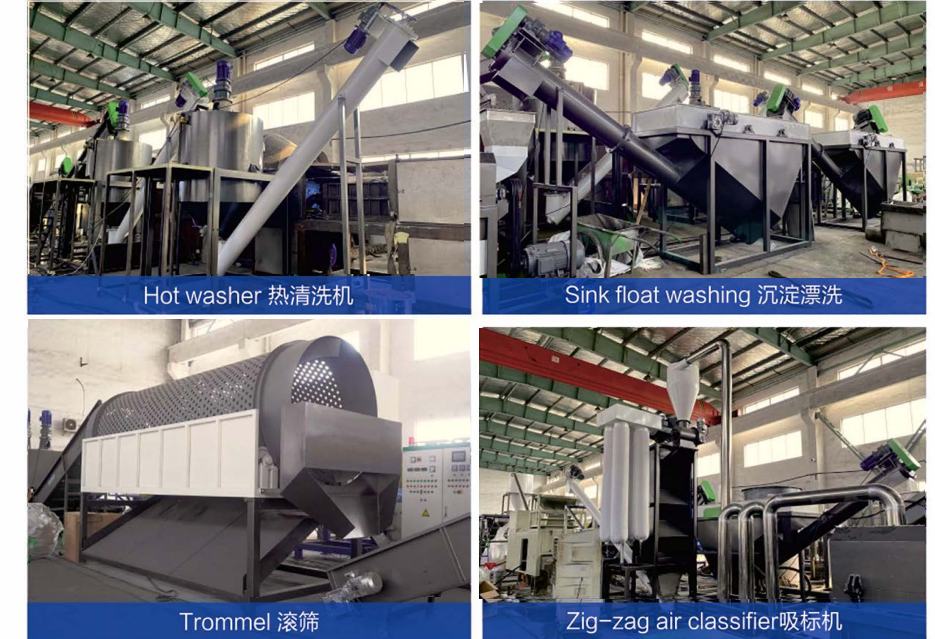

**设备简介 Equipment Introduction**

PET bottle washing recycling line is specially designed for produce PET flakes for fiber use. The flakes can be used for 2-D,3-D PSF, filament yarn, PET strap, PET sheet or PET film. It can adopt the PLC automatic control for the full line. Automatic material sorting system and color sorting system can be chosen optionally. We can configure the machine line according to the raw material and customer needs.



**生产线估算参数 Estimated Plant Parameters**

Capacity(kg/h) 产量 (kg/h)	Power installed(kw) 安装功率 (kw)	Required area(m <sup>2</sup> ) 工厂面积 (m <sup>2</sup> )	Manpower 人力	Water supply(m <sup>3</sup> /h) 用水量(m <sup>3</sup> /h)	Total impurity 总含杂	Flakes size 瓶片尺寸
500	155	300	2-3	4-5	100ppm	12-16mm or according to customer needs
1000	285	500	7-8	5-6		
2000	485	1000	10-12	10-15		

**占地、水电气及人员需求重 Estimated Plant Parameters**

Capacity(kg/h) 产量 (kg/h)	Power installed(kw) 安装功率 (kw)	Required area(m <sup>2</sup> ) 工厂面积 (m <sup>2</sup> )	Manpower 人力	Steam volume(kg/h) 蒸汽量(kg/h)	Compressed Air(m <sup>3</sup> /min) 蒸汽量(m <sup>3</sup> /min)	Water supply(m <sup>3</sup> /h) 用水量(m <sup>3</sup> /h)
500	220	400	8	350	4	1
1000	500	750	10	500	10	3
2000	700	1000	12	800	15	5

# ML PLASTIC FILM RECYCLING PELLETIZING LINE WITH THERMAL-COMPACTOR

## 塑料薄膜压实造粒线

### 设备简介 Equipment Introduction

ML series of multifunctional plastic recycling pelletizing line fits for PE PP film (printed, non-printed), bags, raffia, pre-shredded EPS foam and EPE, and flexible film flakes from washing line. It combines size reduction and pre-heat function in the thermal-compactor to guarantee stable and efficient feeding materials into the extruder. We supply customized machine design and components according to the characteristics of your raw materials and specific requirement.

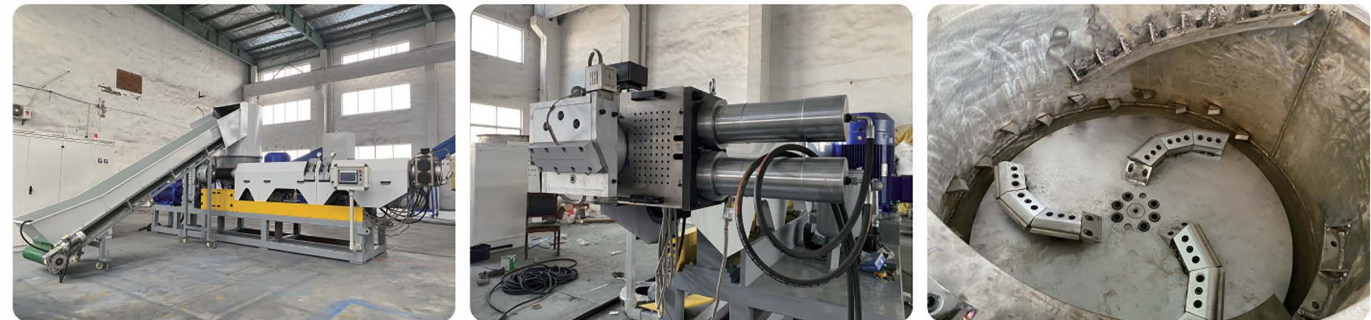
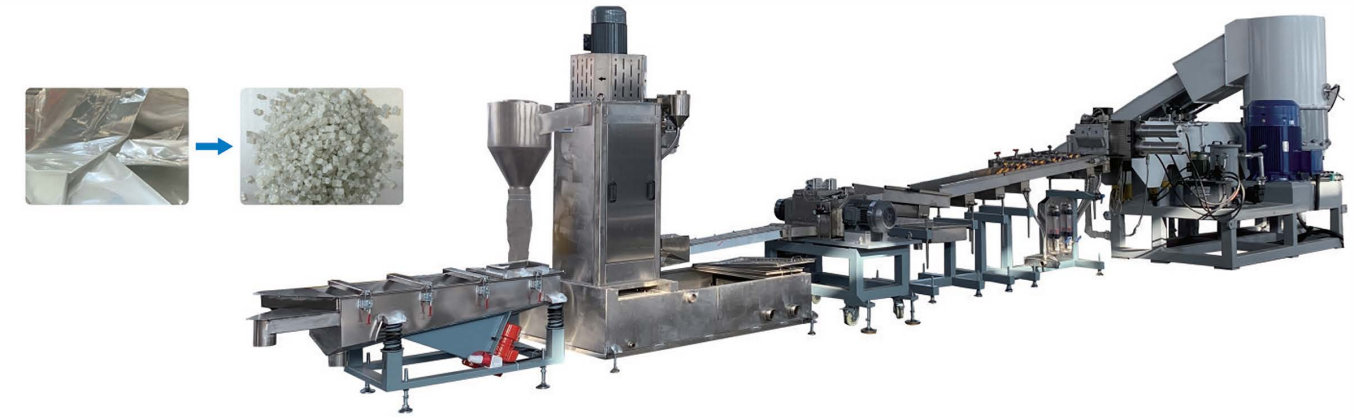
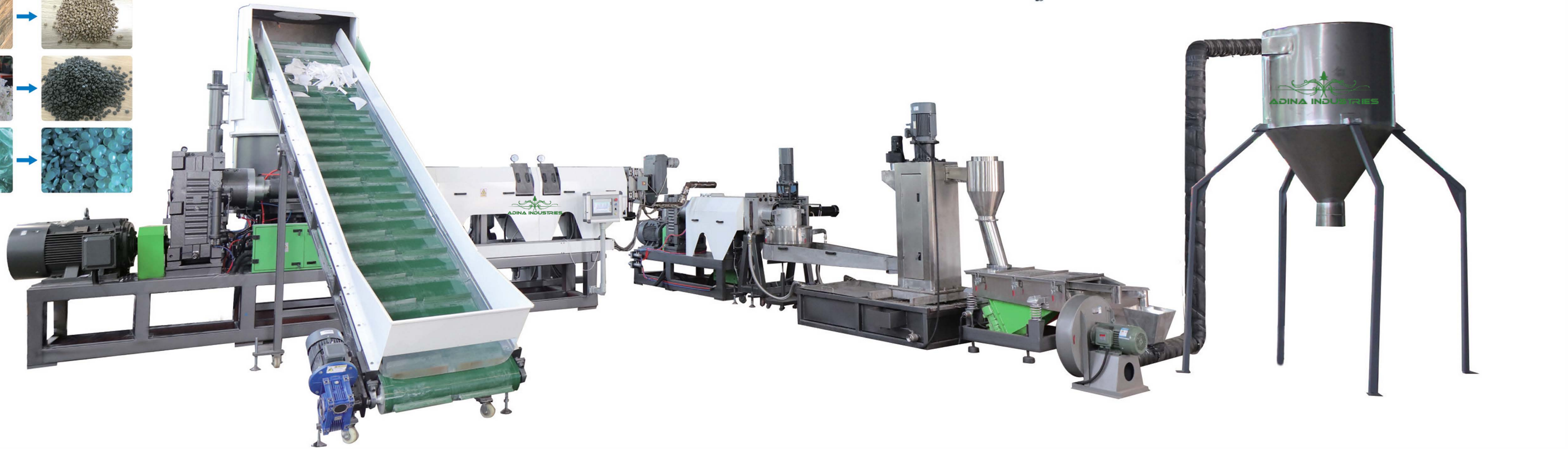
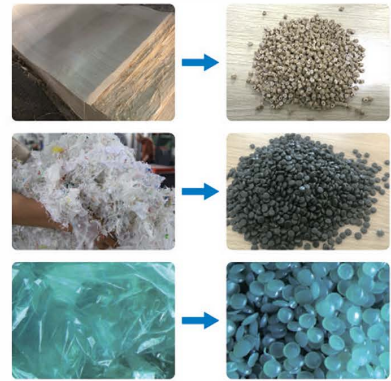

### 主要规格 Main technical parameters

Model	型号	ML85	ML100	ML130	ML160	ML180
Screw diameter(mm)	螺杆直径(mm)	85	100	130	160	180
L/D	长径比	10~38:1	10~38:1	10~38:1	10~38:1	10~38:1
Rotary speed	转速	10~150	10~150	10~150	10~150	10~150
Compactor	密实机直径	EQUIPPED	EQUIPPED	EQUIPPED	EQUIPPED	EQUIPPED
Capacity(kg/h)	产量(kg/h)	180-250	300-400	500-600	700-800	1000-1500

# SJ SINGLE-SCREW PLASTIC RECYCLING PELLETIZING LINE FOR RIGID PLASTICS

## 硬杂料造粒线

### 设备简介 Equipment Introduction

SJ series of plastic recycling pelletizing line fits for rigid flakes such as PE PP agglomerates, ABS PC PS regrinds, squeezed flakes from washing line. Highly automatic control and easy operation, high output up to 1500kg/h. combination of two or three extruders helps to promote pellets quality and production stability. We supply customized machine design and components according to the characteristics of your raw materials and specific requirement.

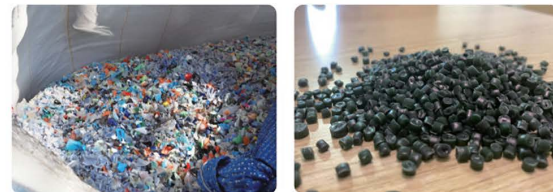
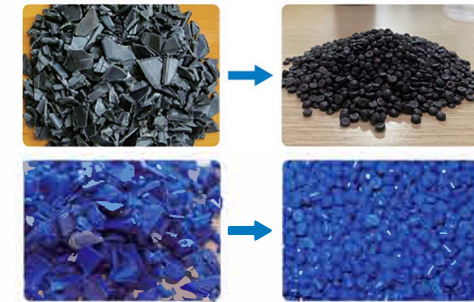

### 主要规格 Main technical parameters

Model	型号	SJ90	SJ100	SJ120	SJ150	SJ160	SJ180	SJ200
Screw diameter(mm)	螺杆直径(mm)	90	100	120	150	160	180	200
L/D	长径比	10~38:1	10~38:1	10~38:1	10~38:1	10~38:1	10~38:1	10~38:1
Rotary speed	转速	10~150	10~150	10~150	10~150	10~150	10~150	10~150
Capacity(kg/h)	产量(kg/h)	150~200	200~300	300~450	500~650	650~800	800~1000	1000~1500



**ADINA INDUSTRIES**  
**SS SINGLE-ROTOR SHREDDER**  
 单轴撕碎机



**设备简介 Equipment Introduction**

SS series single shaft shredder is an economy choice for size reduction of regular plastics: soft film, jumbo bags, raffia, fiber, fish nets, and rigid large start-up lumps, extrusion scraps, offcut, thick pipes, hollow barrels, differ in rotor design. Hydraulic powered pushing plate move forward to push materials against the rotor to be shredded. Highly wear-resisting rotor and knives help users to save cost and maintenance frequency as much as possible.

- Siemens PLC control, first-line brands of electric elements, long service life.
- Various rotor designs according to characteristics of your raw materials and desire.
- First-line brands of motor and gear box, guarantee powerful and stable running.
- Movable feeding hopper can be mounted for long pipes to adjust angle freely.



**主要规格 Main technical parameters**

Model	型号	Ss600	SS800	SS1000	SS1200	SS1500
Motor power(kw)	功率(kw)	22/30	37/45	55/75	75/90	110/132
Capacity(kg/h)	产量(kg/h)	200-400	500-800	800-1000	1000-1500	1500-2000

**DSS DOUBLE-ROTOR SHREDDER**  
 双辊撕碎机



**设备简介 Equipment Introduction**

With two rotors (as in the single-rotor shredder) mounted in a chamber, it achieves ideally double output compared with SS single rotor shredder, designed for soft film.



**主要规格 Main technical parameters**

Model	型号	DSS600	DSS800	DSS1000	DSS1200	DSS1500
Motor power(kw)	功率(kw)	30*2	37*2	55*2	75*2	90*2
Capacity(kg/h)	产量(kg/h)	500-800	800-1200	1000-1200	1200-1500	2000-3000



## HEAVY-DUTY SINGLE-ROTOR SHREDDER WITH SWING RAM

重型摆臂单轴撕碎机

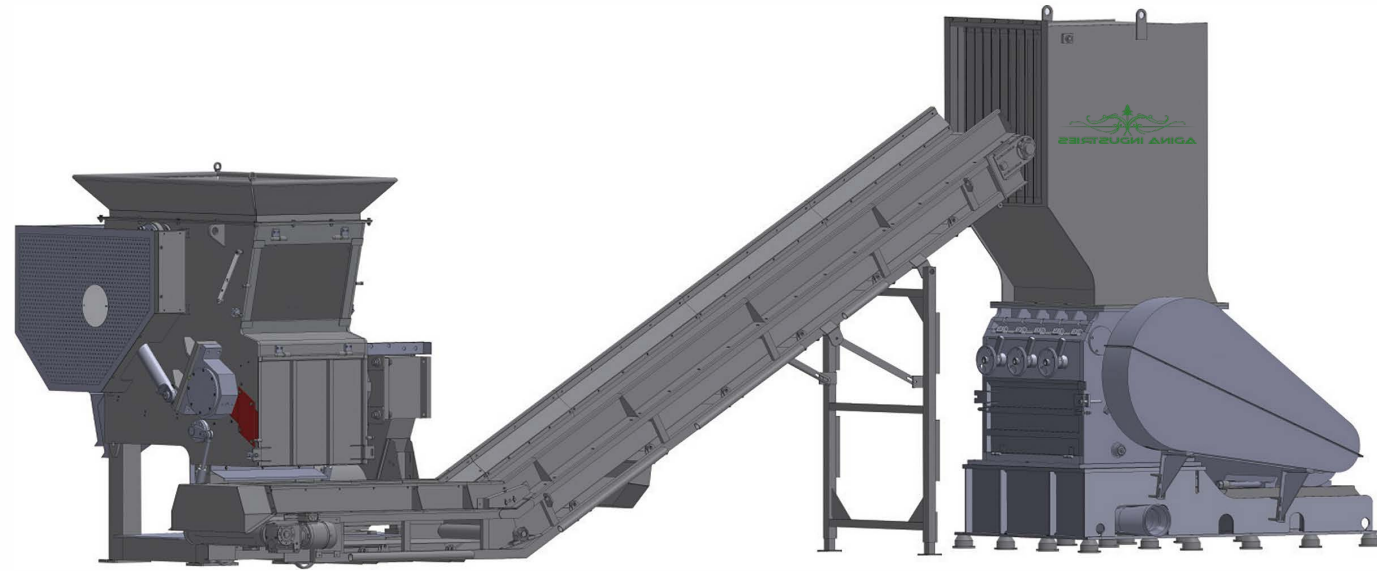

### 设备简介 Equipment Introduction

YPS series heavy-duty single shaft shredder is suitable for both flexible film, jumbo bags, raffia, fiber, fish nets, and rigid large start-up lumps, extrusion scraps, offcut, pipes, hollow barrels, etc. Measuring 500mm in rotary diameter and up to 1450 in length, YPS rotor easily meets your high throughput desires. Hydraulic powered swing ram promotes feeding efficiency. Highly wear-resisting rotor and knives help users to save cost and maintenance frequency as much as possible.

- Siemens PLC control, first-line brands of electric elements, long service life.
- Various rotor designs according to characteristics of your raw materials and desire.
- First-line brands of motor and gear box, guarantee powerful and stable running.
- Distinctive swing arm allows more space for materials and press for higher feeding efficiency.



### 主要规格 Main technical parameters

Model	型号	YPS850	YPS1050	YPS1250	YPS1450
Motor power( kw)	功率(kw)	55	75	90	110
Capacity(kg/h)	产量(kg/h)	500-600	800-1000	1000-1500	1500-2000

## HEAVY DUTY LONG PIPE SHREDDER

重型长管材撕碎机



### 应用 Application

Large diameter pipes such as PE, PVC, PP, and shreds of large diameter bellows.

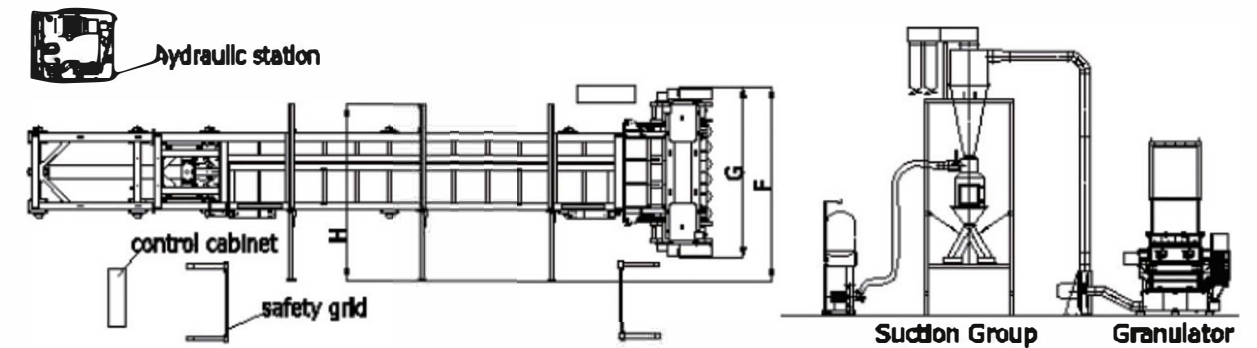
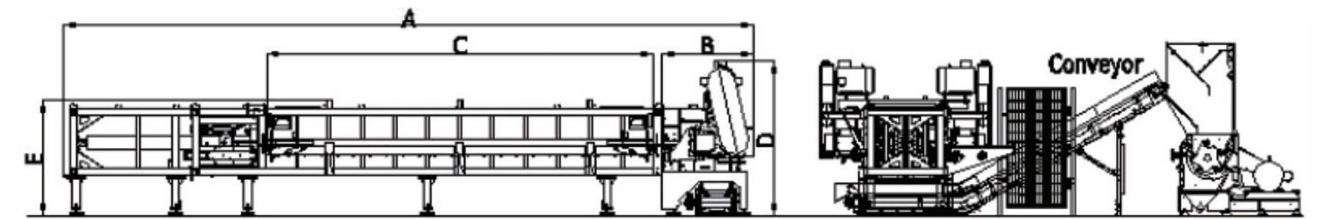

### 主要规格 Main technical parameters

Model	型号	YPS800	YPS1000	YPS1500
Rotor rotary diameter(mm)	转子回转直径(mm)	φ800	φ980	φ1430
Motor power( kw)	功率(kw)	2 × 37	2 × 45	2 × 55
Applicable pipe diameter(mm)	适用管径(mm)	< φ630	< φ800	< φ1000



**设备简介 Equipment Introduction**

DS Series double shaft shredders can handle a wide range of thin and hollow materials such as car tires, plastic bags, film, car bumpers, barrels, drums, wood pallets, woven and non-woven fabrics. High throughput and with overload protection.. Compared to single shaft shredder, this series has lower speed, higher torque, and higher efficiency. It excels in size reducing industrial waste, MSW, electronic waste, waste household appliances and other mixed wastes. Its structure is relatively compact and maintenance-friendly with maintenance door that provides full access to crushing chamber and bearing housing. Because the shredder is screen less, it is often used as primary shredding, and its shredded particle size depends on the blade thickness.

**主要规格 Main technical parameters**

Model	型号	DS650	DS800	DS1000	DS1200	DS1600
Motor power(kw)	功率(kw)	15/22	18.5/30	22 × 2/45	37 × 2/45 × 2	45 × 2/55 × 2
Capacity(kg/h)	产量(kg/h)	500~800	800~1200	1000~1200	1200~1500	2000~3000

**CRUSHER**  
破碎机



**设备简介 Equipment Introduction**

HVC series of heavy-duty crusher is designed for grinding thin plastics such as PE PP film, bags, raffia, woven and non-woven, thin PVC pipes,sheets, profiles, hollow barrels, PET bottles, etc to achieve massive output. A variety of rotor designs according to material characteristics and your desire for downstream process.



**主要规格 Main technical parameters**

Model	型号	HVC500/800	HVC600/800	HVC600/1000	HVC700/1000	HVC600/1200	HVC700/1200	HVC800/1200
Rotor Diameter(mm)	回转直径(mm)	φ500	φ600	φ600	φ700	φ600	φ700	φ800
Rotor Knives(pcs)	动刀(片)	3×2,5×2	3×2,5×2	3×2,5×2	5×2	5×2	5×2,7×2	5×2,7×2
Stator Knives(pcs)	定刀(片)	2x2	2x2	2x2	2x2	2x2	2x2	2x2
Cutting Chamber Dimension(mm)	破碎箱体(mm)	500x780	600x780	600x980	700x980	600x1180	700x1180	800x1180

## PLASTIC PIPE/PROFILE CRUSHER 管材型材破碎机



### 设备简介 Equipment Introduction

Pipe crusher is designed for grinding PVC pipes, sheets, profiles, and thin HDPE PPR pipes. With air conveying and dust collection system you can keep your workshop clean.



## FILM EXTRUDER 薄膜挤干机



### 设备简介 Equipment Introduction

Film squeezer is designed for further drying of thin film and raffia that coming from upstream washing line with high moisture. By power of inner pressing screw materials are squeezed, heated, and diced on the exit die face into semi-melted granules, which are more easily to be fed into the downstream extruder for pelletizing.



### 主要规格 Main technical parameters

Model	型号	JG250	JG300	JG320	JG350
Motor power(kw)	功率(kw)	75/90	110	160	200
Capacity(kg/h)	产量(kg/h)	300-400	400-600	600-800	800-1000



Vacuum Mesh Burner  
真空烧网机



crusher  
粉碎机



Knife sharpener  
磨刀机



Agglomerator  
团粒机



Pelletizer  
切粒机



Screw loader  
螺旋上料机



Color Mixer  
混料机



Burner  
烧网机



Milling Machine  
磨粉机



Grinder  
磨粉机



mixing dryer  
混合干燥机