

ADINA STAUNCH (SVA 6-1.25-BMF)
INDUSTRIAL BIOMASS BOILER

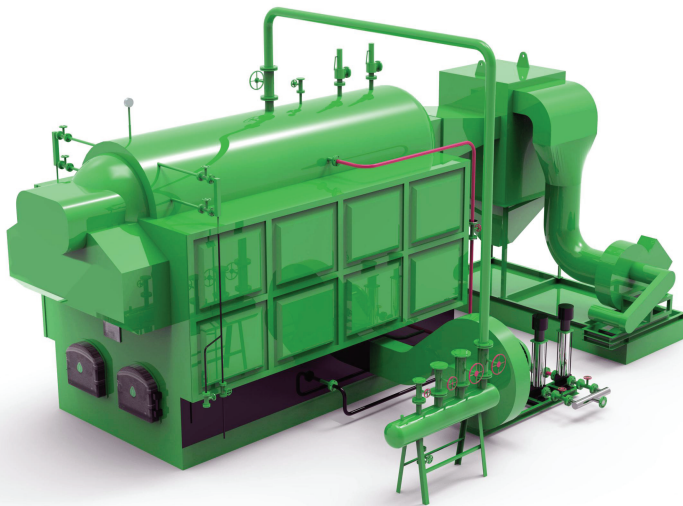

INTRODUCTION

- Working Pressure:1~2.5Mpa
- Working Temp: 184~350
- Capacity: 2~ 35 t/h
- Fuel: Biomass briquette, wood chips, corncob, sawdust, paperboard, wood, light textile
- Application industries: heating, chemical industry, food, tobacco, textile, printing and dyeing, feed, medicine, building materials, wine making, rubber, hospital

FEATURES

- The thermal efficiency of the boiler is greater than 82%, which is higher than the national standard requirement.
- After the water circulation loop is simplified, the water circulation flow resistance is reduced, and the flow velocity in the riser pipe is increased; for the hot water boiler, the left and right water walls with large water circulation flow resistance are equipped with backwater jetting devices. The reliability of the water circulation is improved, and the safe and stable operation of the boiler is ensured.
- Arrange enough heating surface, so that the heat released by fuel combustion can be fully absorbed by the heating surface and then transferred to the working medium, and the exhaust gas temperature is lower than 160 .
- Reasonably arrange the front and rear arches to increase the furnace temperature and at the same time strengthen the disturbance of the flue gas in the high temperature zone, reducing the loss of chemical incomplete combustion and the loss of fly ash.

PRINCIPLE

- Large grate or scale-type grate slices, and ensure that there is enough effective area of the grate, while improving the operating reliability of the grate, ensure that the fuel is fully burned.
- Adopt double-sided air inlet, separate air chamber, independent adjustment, stable combustion and reliable operation. Install the smoke and dust inertial separation device at the outlet of the furnace, so that the original dust concentration of the boiler is lower than 1800mg/Nm³. With the high-efficiency multi-tube dust collector and bag filter, the boiler flue gas emission meets the national first-class area requirements.

Arched tube sheet

- Completely improve the high pressure state above the flat tube plate manhole.
- The degree of fatigue resistance greatly exceeds that of flat tube plates.

Threaded smoke pipe

- Extend the residence time of high-temperature flue gas and enhance heat transfer
- The heat transfer coefficient is 1.8 times higher than that of ordinary smoke pipes

Polar water level electrode

- Except for internationally regulated water level safety settings
- Extra low water level electrode protection
- Interlock with the drum and induced draft fan to ensure the boiler
- Water level safety during operation

Unique three-return design of water and fire pipe

- The high-temperature flue gas first enters both sides of the body from the tail
- Eight-character flue (water pipe type)
- The cooled flue gas enters the drum from the front smoke box

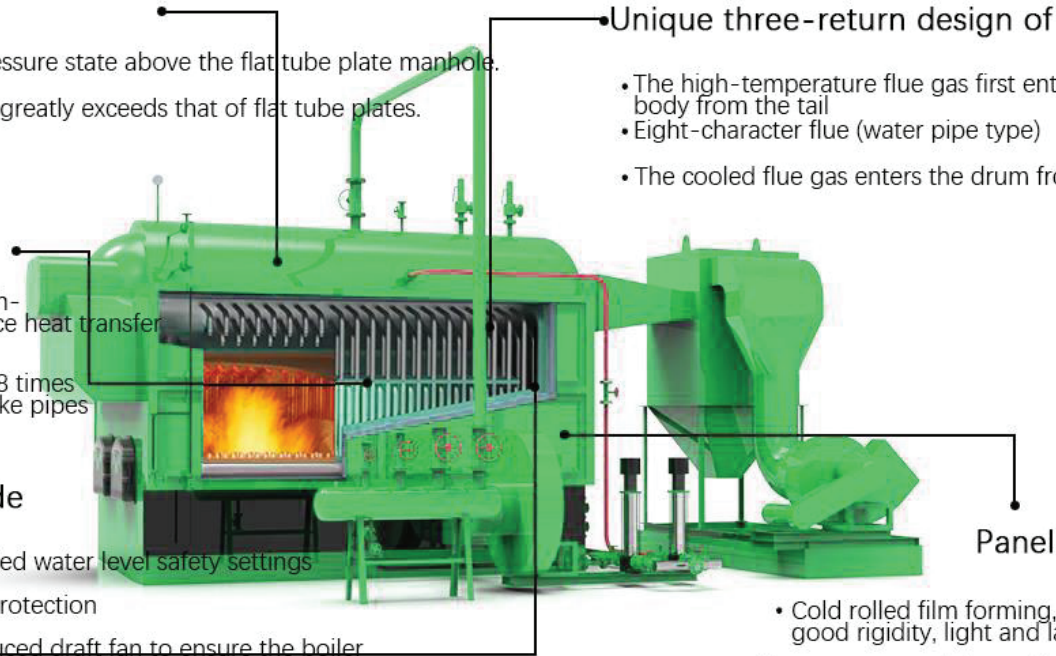

- Cold rolled film forming, concave-convex panel, good rigidity, light and large
- After rust removal, the surface is coated with primer and topcoat, which has good anti-corrosion effect.



1	2	3	4	5	6	7	8	9	10
Boiler Body	Safety Valve	Sub-Cylinder	Blower	Dust Collector	Flue	Induced Draft Fan	Circulating Pump	Steam Pipes	Combustion Chamber

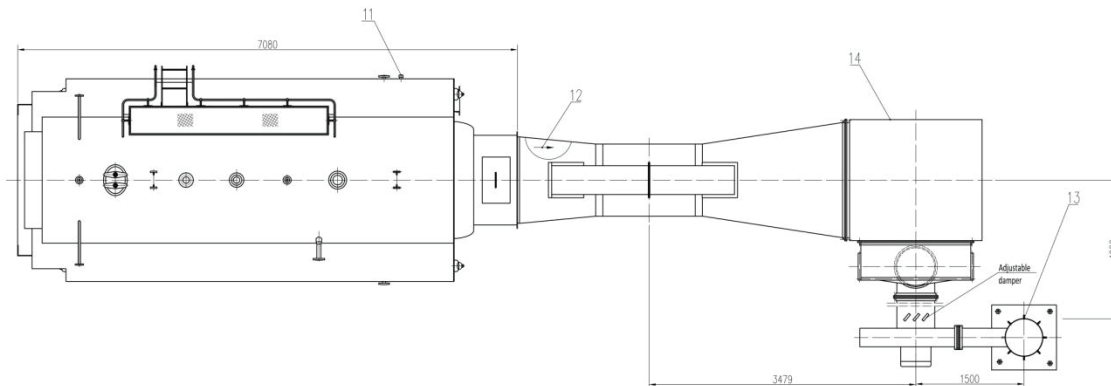
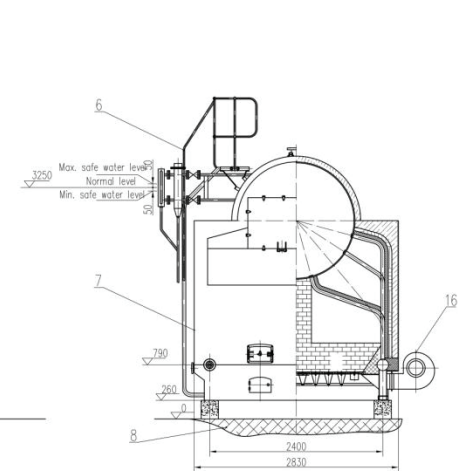
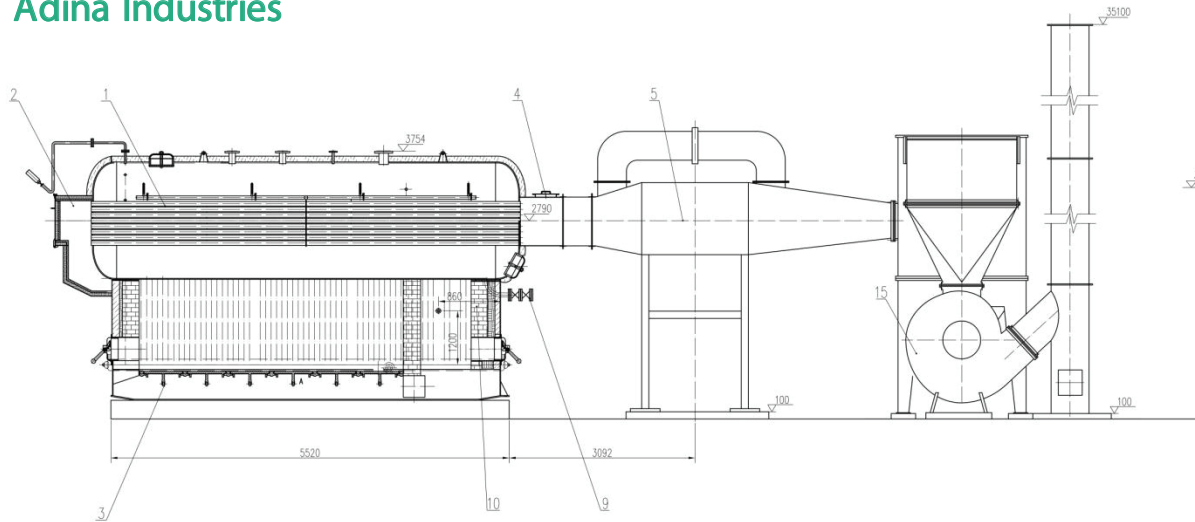

Technical Requirement

1. The design, Manufacture, Inspection, Installation and use of the boiler shall meet the requirements of the following standards:

- 1) TSGG0001-2012 Boiler Safety Technology Supervision(Including amendment NO. 1)
- 2) GB50273-2009 Boiler Installation Construction and Acceptance Specifications.
- 3) GB/T47034-2013 Industrial Boilers Technical Requirements
- 4) GB/T1576-2008 Industrial Boiler Water Quality Requirements
- 5) GB13271-2014 Emission Standard of Boiler Air Pollution.
- 6) GB/T16508-2013 Shell Boiler
- 7) NB/TT47062-2017 Industrial Incineration Boiler

2. The energy-saving requirements of the boiler shall comply with the requirements of TSG G0002-2010 Regulations on Supervision and Management of Boiler energy saving technology (including NO.1 Amendment)

3. Boiler paint and packaging shall meet the requirements of NB/T47055-2017 General Technical Conditions For Boiler Coating And Packaging

4. The safety valve, blowdown valve, water level gauge and drain pipe must be connected to a safe place.

Main Parts Details

Item	Unit	Qty	Parameter
Boiler Body	Set	1	Transportation size dimension:7080×2830×3520 ;Weight:26.3t
Blower	Set	1	G6-41-11 NO7.1A; Motor power:7.5Kw
Induced Draft Fan	Set	1	Y6-41-11 NO9C: Motor power:37Kw
Electric Control Cabinet	Set	1	Touch display,Electrode water level control, over pressure alarm, overload alarm function, water shortage and full water alarm function, etc.
Instrument /Valves	Set	1	The body includes a complete set, and the main valve including vulnerable spare parts.
Economizer	Set	1	36pcs &60*1.5m
Sub Cylinder	Set	1	One in and Three Out
Boiler Water Sampler	Set	1	LSQYQ-4
Feed Pump	Set	1	KQDP40-8S×18; flow rate:8m³/h; pump head:153m; Motor Power:7.5KW
Multiclone Dust Collector	Set	1	China Origin
Water Treatment Equipment	Set	1	Unattended, the hardness of treated water reaches the national standard.
Chimney	Set	1	Ø600, Height:15m
Stoker Tools	Set	1	

Data Table

1. Boiler

Rated Evaporation	6 t/h	Rated working pressure	1.25MPa
Rated Steam Temperature	193°C	Feed water temperature	20°C
Hydrostatic test pressure	1.65MPa	Radiant heating area	8.88m ²
Convective heating area	156.07m ²	Heating area of economizer	78.48m ²
Design thermal efficiency	82.6%	Exhaust gas temperature	144.47°C
Fuel type and low calorific value	SC I:16704KJ/Kg		
Water capacity of boiler	10.4m ³	Effective area of grate	7.5m ²
Max. transportation weight of boiler parts	24.5t	Transportation dimension (L*W*H)	7080*2830*3520
Front tube sheet	DN1628*14;Q245R	Installation size (L*W*H)	14700*4213*4500
Rear tube sheet	DN1628*14;Q245R	Boiler shell(OD*T*L)	φ1628 *14;Q245R
Threaded smoke pipe (OD*T*L)	φ70 *3.5 *5872;	Material / quantity	20#/98
Water-cooled wall (OD*T*L)	φ51 *3 *2030;	Material / quantity	20#/111
Header(OD*T*L)	φ159 *6 *5510;	Material / quantity	20#/2
Down tube (OD*T*L)	φ133 *6 *1595;	Material / quantity	20#/4
Manhole specification	300*400	Specification of access door hole	DN400

2. Valves and Instruments

Model and specification of main steam valve	J41H-16C, DN150	Qty. of main steam valves	1pcs
Model and specification of auxiliary steam valve	J41H-16C, DN40	Qty. of auxiliary steam valves	1pcs
Model and specification of safety valve	A48H-16C, DN80	Qty. of safety valves	2pcs

Data Table

Model and specification of periodic blowdown valve	P48H-16C;DN50	Qty. of periodic blowdown valves	6pcs
Model and specification of water supply valve	J41H-16C;DN40	Qty. of feed water valves	1pcs
Model and specification of feed water check valve	H41HT-16C;DN40	Qty. of feed water check valves	1pcs
Model and specification of glass plate water level gauge	X49H-25;DN25 Spacing:350	Quantity of glass plate water level gauge	2pcs
Model and specification of electric contact pressure gauge	YX-150; Range:0~2.5MPa	Qty. of electric contact pressure gauges	1pcs
3. Auxiliary Equipment:			

Feed water pump: Model:KQDP40-8S×18; Flow rate:8m³/h; Head :153m; Motor Power:7.5KW; Qty.: 2pcs

Blower: Model: G6-41-11 NO7.1A; Air flow:7852m³/h; Air pressure:1984Pa; Motor Power:7.5Kw; Qty.:1set

Induced draft fan: Model:Y6-41-11 NO9C; Air flow:21823 m³/h; Air pressure:3677Pa; Motor Power:37Kw; Qty.: 1set

Secondary induced draft fan: Model:9-19-4A; Air flow:3105m³/h; Air pressure:3380Pa; Motor Power:37Kw; Qty: 1set

Chimney :φ600; Height:15m



Contact

Adina Industries Co.,Ltd

Rm802,Building D,Shangduan Tower,Yucheng Street,Yuhuan City,Zhejiang Province China

Email:asifbeg@adinaindustries.com eric@adinaindustries.com

Phone:+86 177 8729 9186 +86 138 6762 7459